

Model / Model : **A4-150 VVVF 1000-1,0**

Kontrol / Control	:	VVVF/ Encoder
Askı / Roping	:	1 / 1
Yük / Load	:	1000 Kg
Hız / Speed	:	Max. 1,0 m/s
Motor / Motor	:	380 VAC / 50Hz
Motor Gücü / Motor Power	:	10 Kw
Devir / Motor RPM	:	1500 RPM
Akım / Motor Current	:	23 A
Aktarma Oranı / Ratio	:	40 / 1
Kasnak-Hatve / Sheave-Pitch	:	ø480 x 6 x ø10 / 16
Kanal Açısı / Groove Angle	:	40°
Fren / Brake Magnet	:	195 VDC
Yağ-Kapasite / Gear Oil-Capacity	:	Mobil Gear 600 XP320 / 5Lt.
Maks. Statik yük / Max. Static Load	:	4000 Kg

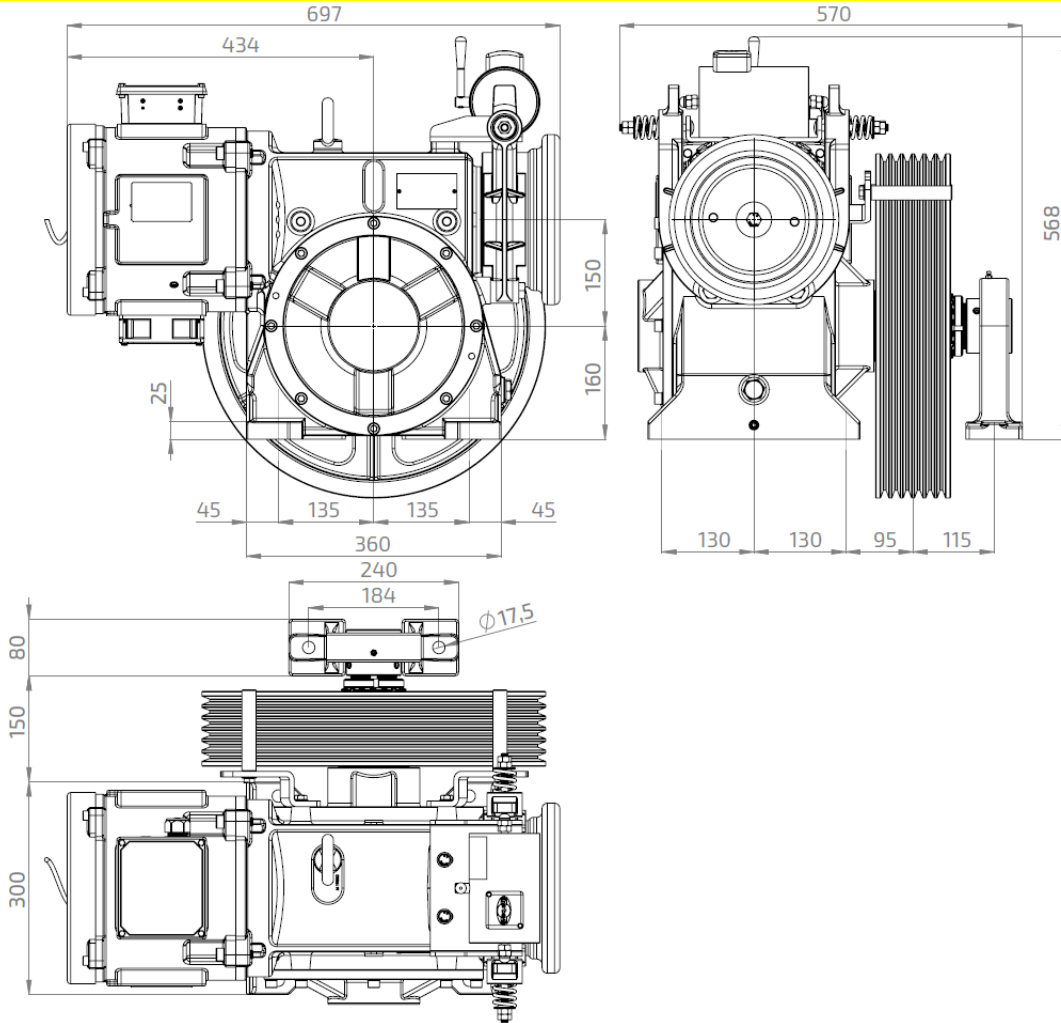

Astes Asansör ölçüler ve veriler üzerinde değişiklik yapma hakkına sahiptir.

The dimensions and data are subject to change without notice.