

Model / Model : **A4-180 VVVF 3000-0,63**

Kontrol / Control	:	VVVF/ Encoder	
Askı / Roping	:	2 / 1	
Yük / Load	:	3000 Kg	(2/1)
Hız / Speed	:	Max. 0,63 m/s	(2/1)
Motor / Motor	:	380 VAC / 50Hz	
Motor Gücü / Motor Power	:	15 Kw	
Devir / Motor RPM	:	1500 RPM	
Akım / Motor Current	:	32 A	
Aktarma Oranı / Ratio	:	60 / 2	
Kasnak-Hatve / Sheave-Pitch	:	ø480 x 6 x ø12 / 19	
Kanal Açısı / Groove Angle	:	40°	
Fren / Brake Magnet	:	195 VDC	
Yağ-Kapasite / Gear Oil-Capacity	:	Mobil Gear 600 XP320 / 8Lt.	
Maks. Statik yük / Max. Static Load	:	10000 Kg	(2/1)

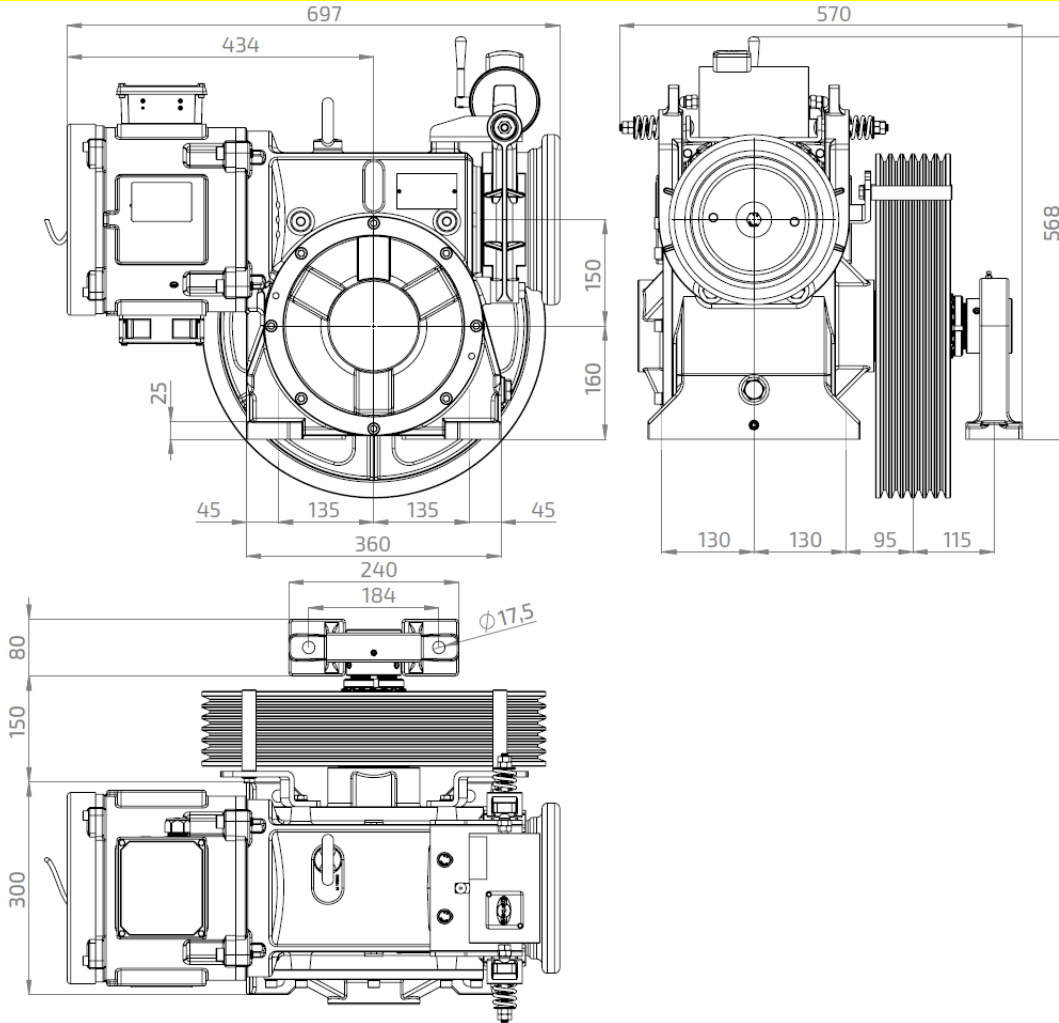

Astes Asansör ölçüler ve veriler üzerinde değişiklik yapma hakkına sahiptir.

The dimensions and data are subject to change without notice.